

FORMAX[®]

FD 2000 / FD 2030

AutoSeal[®]

OPERATOR MANUAL
THIRD EDITION

TABLE OF CONTENTS



DESCRIPTION	1
SPECIFICATIONS	1
UNPACKING AND SET-UP	1
CONTROLS	2
OPERATION	2
FOLD PLATE ADJUSTMENT	3
Setting Custom Folds	3
DAILY MAINTENANCE	4
TROUBLESHOOTING	5
OPTIONAL CONVEYOR INSTALLATION	6

DESCRIPTION



FUNCTION

The 2000/2030 folds and seals pressure sensitive forms with pre-applied glue lines into mail-ready pieces. Numerous folds using several different paper sizes can be processed to meet your needs. For configurations and paper sizes, see specifications.

SPECIFICATIONS

Maximum foldable paper size	14" length x 8.5" width
Fold styles	"C", "Z", "V" and custom folds
Paper loading capacity	Up to 350 sheets of 24 # pre-glued forms
Weight	90 lbs.
Power supply	FD Model: 120 volts, 60 Hz, 3.5 amps. FE Model: 240 volts, 50 Hz, 3.5 amps.

UNPACKING AND SETUP

1. Check package for shipping damage. If there is shipping damage, do not discard the box.
2. CAUTION: Two people must lift the machine out of the box.
3. Remove the accessory bag which is between the machine and the catch tray.
4. Place the jam clearing handle into the holder which is mounted to the machine. This is the jam clearing handle's proper location (figure 1).

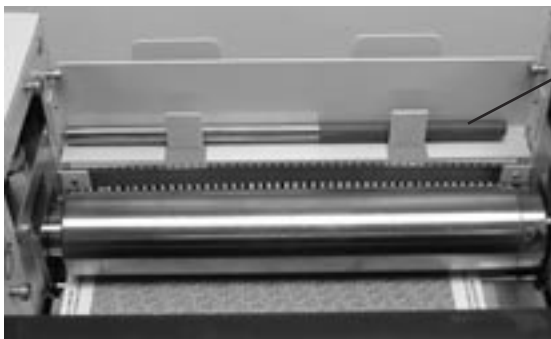

Jam clearing handle location

(Figure 1)

CONTROLS



- Start Starts machine.
- Stop/ Reset..... Stops machine / clears “fault” condition.
- Jog..... Allows one piece of paper to feed at a time. Used for paper fold settings.
- Power..... Light comes on when power is on.
- Cover open..... Light comes on if either top cover or side cover is open.
- Paper out..... Light comes on when infeed paper tray is empty.
- Fault detect..... Light comes on if there is a paper jam.
- Reset..... Resets counter.
- Counter..... Shows forms count.

OPERATION

1. Adjust fold plates to desired fold for length of paper (see Fold Plate Adjustment on page 3). To do this, first loosen two thumbscrews on each fold plate. Align center bar so the marks on each side match up. For “V” folds remove the lower fold plate, turn around 180° and reinstall.
2. Load neatly stacked and squared paper into the hopper. Paper can be stacked up to 150 sheets for the FD2000 and up to 225 sheets for the FD2030. Note: Standard “Z” fold forms can be loaded face up or down with the glue edge leading. All “C” fold forms must be loaded face up with glue edge leading.
3. Make sure covers are closed properly.
4. Plug in cord and turn power on.
5. Press jog switch to make sure folds are correct; adjust if necessary (see Fold Plate Adjustment, page 3).
6. Press the start button to begin operation.

FOLD PLATE ADJUSTMENT

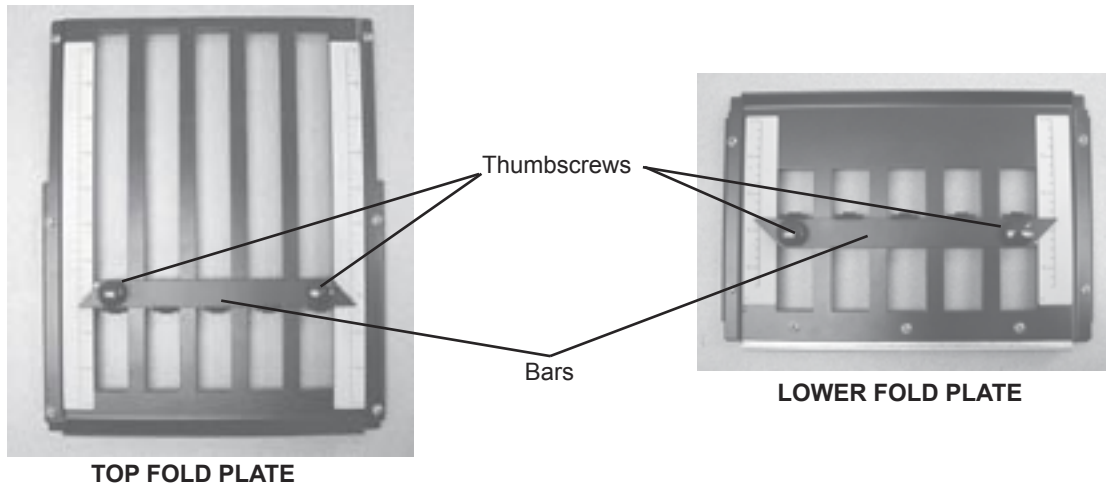

1. To adjust the first fold, open the top cover to access the top fold plate. If the first fold is too long, loosen the two thumbscrews and slide the bar down. If the fold is too short, loosen the thumbscrews and slide the bar up.

NOTE: The bar should be on the same marks on each side.

2. To adjust the second fold, remove the lower fold plate. If the second fold is too long, loosen the two thumbscrews and slide the bar up. If the fold is too short, loosen the thumbscrews and slide the bar down.

NOTE: The bar should be on the same marks on each side.

3. For quick setup of “C”, “Z” and “V” folds, look for the blue lines on the fold plate.

Setting Custom Folds

Example 1: Uneven “Z”

1. Measure the length of panel “A”

2. Adjust the upper fold plate so that the bar lines up with the measurements of panel “A,” i.e. if panel “A” is 5 1/4” long, move the bar up or down so that it lines up with the 5 1/4” mark on the fold plate.

3. Measure the length of panel “B”

4. Adjust the lower fold plate so that the bar lines up with the measurements of panel “B”.

5. Load forms and press start (refer to OPERATION on page 2).

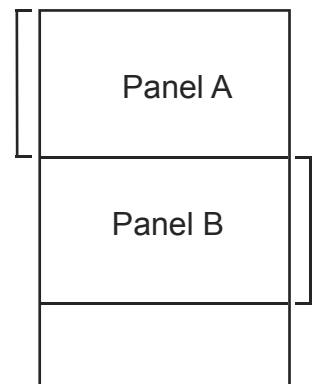

Example 2: Uneven “C”

1. Measure the length of panels “A” + “B”

2. Adjust the upper fold plate so that the bar lines up with the measurements of panels “A” and “B,” i.e. if panel “A” and “B” are 10 1/2” long, move the bar up or down so that it lines up with the 10 1/2” mark on the fold plate.

3. Measure the length of panel “B”

4. Adjust the lower fold plate so that the bar lines up with the measurements of panel “B”.

5. Load forms and press start (refer to OPERATION on page 2).

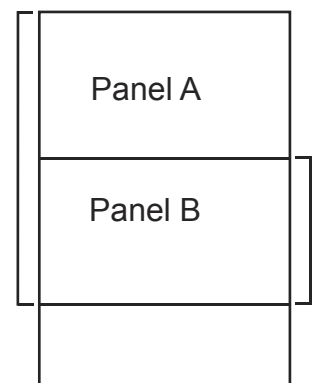

DAILY MAINTENANCE

1. It is recommended to let forms cool for one-half hour, from the laser printer, before folding and sealing. This allows toner to set on the forms, and static electricity to discharge. A 400 Series Jogger is recommended for best results. The Jogger squares the forms and dissipates heat and static electricity created by laser printers.
2. If toner builds up on the metal sealer rollers, clean the rollers with a lint-free cloth dampened sparingly with a mild household cleaner.
3. Clean in-feed wheels and fold rollers with Formax recommended roller cleaner & rejuvenator to remove paper dust and toner. A damp cloth with water is the best alternative. CAUTION: Do not use any chemicals other than the roller cleaner & rejuvenator or water.

TROUBLESHOOTING

A. Clearing Paper Jams and Fault Signals on the Display Panel:

WARNING: Turn off machine and unplug cord from its receptacle.

1. If a jam occurs in a fold plate, unplug and remove the fold plate and remove paper. Reinstall fold plate and then press the reset button on the control panel to clear the fault signal.
2. If a jam occurs in between the metal sealing rollers, remove any remaining forms from the hopper. Open the top cover and remove the upper fold plate. Remove the jam-clearing tool (located under the top fold plate), apply the tool to the upper metal roller (figure 2a) and turn clockwise until the paper jam is clear. (**Caution:** Do not apply excessive force or rollers may be damaged.) (**Caution:** Do not turn counter-clockwise and force the form(s) to exit the machine or the rollers may be damaged.). Remove the jammed form, return tool to holder and reinstall the upper fold plate. Reinstall cover and press the reset button.

Note: Press the black button near the power cord inlet to reset the breaker if necessary (figure 2b).



Figure 2a

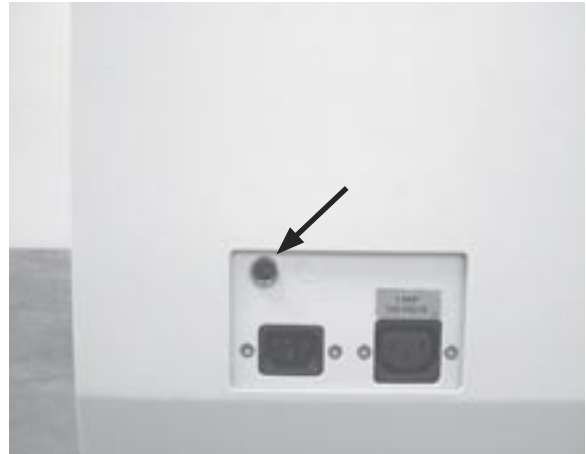

Figure 2b

B. Paper Pulls Left or Right During Feeding:

1. Adjust the side guides to the edge of the forms.
2. Clean the three infeed wheels with a cloth dampened with a mild household cleaner.

C. Skewed Forms

1. If paper folds left or right, adjust the skew adjuster. To adjust the skew, turn it left or right until the paper is feeding correctly and folds squarely (figure 3).



Figure 3

2. Side guides should be adjusted so that the forms do not have free play between the guides.

OPTIONAL CONVEYOR INSTALLATION

To install the 18" conveyor, follow these steps:

1. Unplug the 2000/2030 from the wall outlet.
2. Remove upper fold plate.
3. Turn the machine onto the non-operator side and remove the catch tray from machine. Return the machine to its upright position.
4. Plug the power cord into the underside of the conveyor.
5. Install conveyor mounting bolts (figure 4).
6. Attach the conveyor to the 2000/2030.
7. Install the stacker wheel assembly into the holes indicated in figure 5.
8. Adjust the stacker wheels to conveyor decal (figure 5).
9. Plug the conveyor power cord into the power outlet on the 2000/2030.
10. Reinsert the upper fold table.
11. Plug the 2000/2030 into the wall outlet.

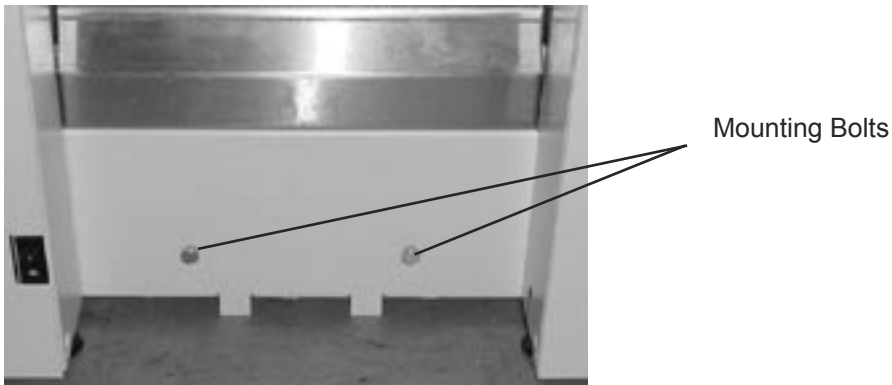

Figure 4

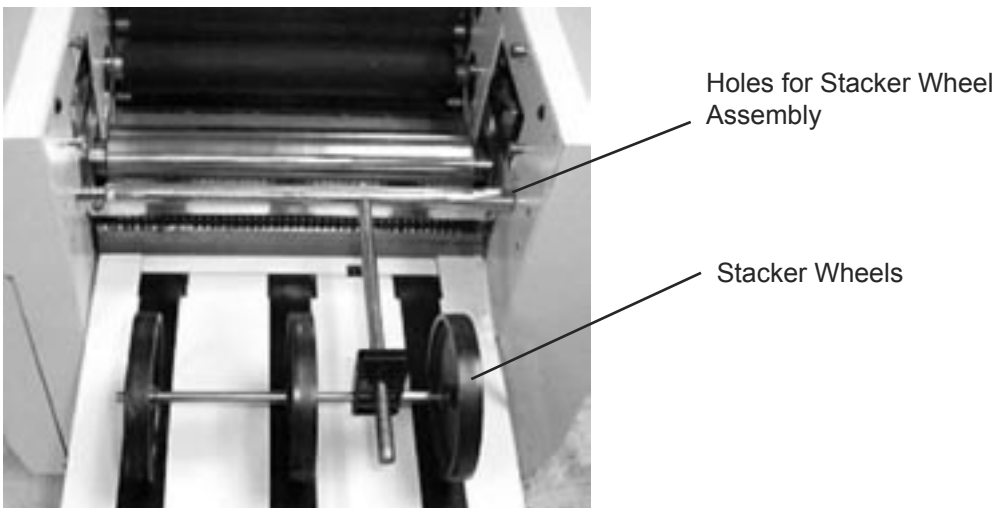

Figure 5